



SS200

Sun sensor

The SS200 is a small-size, low-mass and low-power sun sensor for use in satellites.

The sampling rate is adjustable, allowing the user to trade bandwidth against power consumption.

The SS200 can be seamlessly integrated with Hyperion Technologies' line of integrated attitude determination and control systems to provide a fully integrated ADCS solution.

The SS200 has a field of view of up to 110 degrees to allow for a smooth transition between the measurement ranges of two sun sensors on adjacent faces of the satellite.

The SS200 delivers below 1 degree accuracy in the +/-45 degree range, and is calibrated on delivery.



Flight heritage since 2018

HIGHLIGHTS

- Mass: 3 g
- Power consumption (active) 2.5-40 mW
- Sampling rate up to: 100 Hz
- Accuracy (+/- 45°) <1°
- Total field of view 110°
- I²C-compatible interface





SPECIFICATIONS

Performance		
Field of view	110	°
Accuracy (+/- 45° range)	<1	°
Sampling rate	up to 100	Hz
Environmental		
Operating temperature (electronics) ¹	-45 to +85	°C
Operating temperature (sensor)	-55 to +125	°C
Radiation tolerance	> 36	krad (Si)
Electrical specifications		
Supply voltage	5	V
Power consumption ² (sampling)	2.5-40	mW
Power required (idle)	< 1.5	mW
Mechanical		
Outer dimensions	24.66 x 15.00 x 3.50	mm
Mass	3	g

¹ Temperature range of control electronics. Functionality of mechanical components and sensor extends beyond this range.

² Power consumption dependent on sampling rate

MECHANICAL CHARACTERISTICS (IN MM)

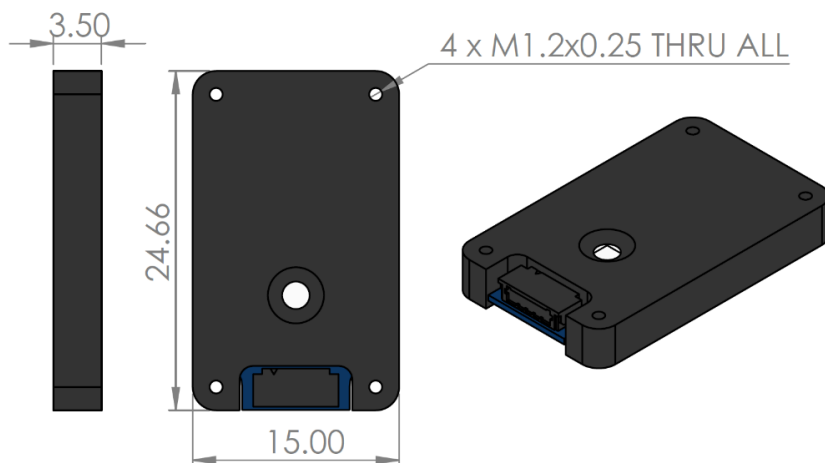

For pricing, delivery, configuration and ordering information please contact us
at sales@hyperion.space or call us at +31(0)15-5160905

